

SSOW 32: ASSEMBLY & DISASSEMBLY OF 50T EXCAVATOR BOOM & COUNTERWEIGHT FOR TRANSPORT

Issue Number: 02

Date of Issue: 31/01/2026

Based on: RA92

PURPOSE

To ensure the safe removal and installation of the boom (with dipper arm cylinder) and counterweight from a 50T tracked excavator during transport preparation and reassembly. This SSOW sets out the safe working practices, competency requirements, and equipment standards required to carry out lifting, disconnection, and reassembly activities in accordance with RA92, manufacturer guidance, and site-specific rules.

PPE REQUIREMENTS

For this activity, the following PPE must be worn

					
<input checked="" type="checkbox"/>	<input checked="" type="checkbox"/>	<input checked="" type="checkbox"/>	<input checked="" type="checkbox"/>	<input type="checkbox"/>	<input type="checkbox"/>
High-vis Vest / Jacket (BS EN 471)	Safety Boots (EN ISO 20345:2011) (S3)	Safety Gloves (Cut resistant) (EN 420:2003)	Safety Helmet (EN 397:1995)	N/A	N/A

TRAINING REQUIREMENTS

- Competent and authorised fitters and operators only.
- Valid CPC/CPORS cards for lifting operations (e.g. A59C, A68).
- Familiarity with RA92, manufacturer instructions, and hydraulic isolation procedures.
- Working at height competence (e.g. CPORS N404) where access equipment is required.
- Manual handling training (RA11) for handling components and accessories.
- Understanding of PUWER/HAHR requirements for access equipment.
- Awareness of lifting capacity limits, exclusion zones, and emergency procedures.

EQUIPMENT REQUIREMENTS

- Lifting equipment and accessories with valid thorough examination certificates.
- Access equipment (e.g. mobile towers) with guardrails and inspection records.
- Spill kits for hydraulic oil containment.
- Warning signage and physical barriers for exclusion zone control.
- Manufacturer-approved tools for hose disconnection, pin removal, and component handling.
- Timber blocks for safe component placement during disassembly.

SAFE SYSTEM OF WORK

- Only trained, competent, and authorised personnel (e.g. designated plant workshop fitters) may carry out machine disassembly/lifting activities.
- Excavator operators must hold valid CPC/CPORS cards for lifting operations (e.g. A59C, A68) and be competent in hydraulic isolation procedures.
- All personnel must be briefed on the risk assessment and site-specific emergency procedures before starting work.
- The work area must be physically segregated using barriers; access to be restricted to essential personnel only.

SSOW 32: ASSEMBLY & DISASSEMBLY OF 50T EXCAVATOR BOOM & COUNTERWEIGHT FOR TRANSPORT

Issue Number: 02

Date of Issue: 31/01/2026

Based on: RA92

- All lifting equipment and accessories must be serviceable, defect-free, and suitable for the task, with a valid thorough examination certificate or certificate of conformity if newly supplied.
- User pre-use checks must be completed on all equipment and accessories before work begins. Any safety-critical defects must result in immediate quarantine of the item and the line manager notified.
- Equipment / accessories safety-critical defects must be reported immediately, and only authorised individuals are permitted to carry out repairs.
- **The manufacturer instructions must be followed at all times.**
- Where work at height is unavoidable, suitable access equipment (e.g. mobile towers) must be used. Work from ladders is only permitted where site constraints prevent platform use. Personnel must hold NPORS N404 or equivalent, and all access equipment must be fitted with guardrails and inspected in accordance with PUWER/WAHR regulations.
- When entering, exiting, or climbing the machine, personnel must use designated handrails and steps, maintaining three points of contact and facing the machine. Fixed guard rails are provided.
- The hydraulic system must be fully depressurised before any disassembly work begins.
- Any spills must be contained and cleaned up immediately using spill kits provided.
- All incidents, accidents, or near misses must be reported immediately (once safe to do so), and local emergency procedures must be followed.
- The excavator operator must ensure the machine is positioned on suitable ground, confirm the landing area is safe, and verify that only authorised personnel are present within the segregated zone. A test lift should be conducted to confirm load security; operations must be stopped if safety concerns are raised.
- **Working directly underneath a lifted load is strictly prohibited.**
- Lifting operations must never exceed the machine's rated object handling capacity for the given configuration, radius, and height. This includes accounting for the weight of any attachments (e.g. quick hitch, bucket, lifting accessories) which must be deducted from the rated capacity if not already included.

Removal of boom with dipper arm cylinder

- Position machine on firm, level ground in designated workshop area.
- Stop the engine and allow it to cool down.
- Isolate controls.
- Release the hydraulic system pressure. Residual pressure in the hydraulic system can lead to oil under high pressure jetting out and cause serious injury, even if the engine has not been running for some time.
- Disconnect the hoses at point (B) (hoses for hammer and shear) and drain the oil (COSHH controls apply).
- Disconnect the wire harness on the boom.
- Plug pipes and hoses with appropriate tool at disconnected points. Secure loose hydraulic hoses to the boom (cable ties) to prevent these from interfering with other machine components (where required).

Owner: Head of HSQE	Version: 2	LF266
Uncontrolled if printed or copied. Always check for latest version.		Page 2 of 4

SSOW 32: ASSEMBLY & DISASSEMBLY OF 50T EXCAVATOR BOOM & COUNTERWEIGHT FOR TRANSPORT

Issue Number: 02

Date of Issue: 31/01/2026

Based on: RA92

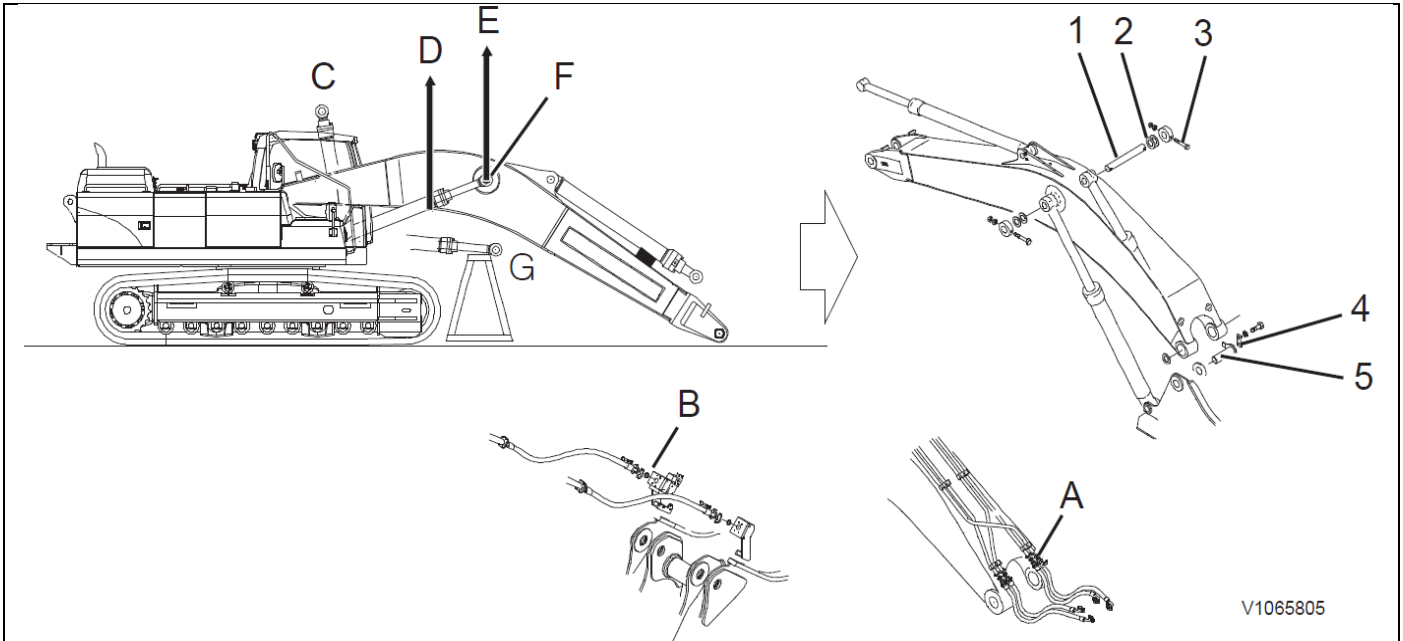

- Lift the boom cylinder (left side of D) slightly. Use cable sheath and be careful that the cylinder is not damaged.
- Remove the locking pins (3) at point (F) and the push pin (1) to the right side.
- Start the engine.
- Retract the boom cylinder completely and lower the boom cylinder on the bedplate (G).
- Turn off the engine and isolate the machine.
- Repeat the process for the opposite side.
- Reinstall the pin at point (F) again with shims and locking screws. Ensure that the locations of locking screws (3) and shims (2) are not changed into right side ones.
- Hitch the cable at point (F). Use cable sheath to not damage the pin.
- Remove the locking plates (4) and pins (5).
- Lift the boom with dipper arm cylinder and lower that on the ground. Insert a timber block below the boom (if required).
- Tie dipper arm cylinder rod to prevent movement
- Reinstall the pins (5) and locking plates (4) and secure for transport.

Counterweight removal

- Isolate controls and attach warning label to prevent unintended engine start.
- Remove the three plug crews from the top of the counterweight.
- Connect lifting chains/slings to designated lifting points using 3 eye bolts lifting points (A) and (B) (spec: M48-P5).
- Disassemble 8 securing screws (C).
- Lift counterweight slowly and steadily.
- Lower to ground or place on stable timber blocks if surface is uneven.
- Ensure the exclusion zone is maintained throughout lift.

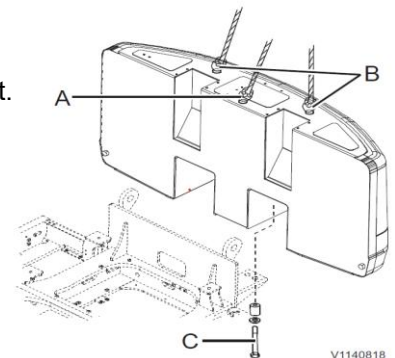

SSOW 32: ASSEMBLY & DISASSEMBLY OF 50T EXCAVATOR BOOM & COUNTERWEIGHT FOR TRANSPORT

Issue Number: 02

Date of Issue: 31/01/2026

Based on: RA92

IDENTIFIED RISKS

The SSOW above has been compiled after identifying the following risks from this activity

- Cut/Crush Injuries
- Hydraulic Burns/Injection
- Working at Height
- Accidental fuel spills
- Equipment Failure (incl. lifting accessories).
- People Plant Interface
- Loss of load (drop/slip)
- Ground Instability
- Visibility/Communication
- Slip/Trip/Fall
- Manual Handling
- Unintended plant movement
- Load swing or drop
- Machine overturning

FOR MORE INFORMATION, PLEASE REFER TO RISK ASSESSMENT RA92

Owner: Head of HSQE	Version: 2	LF266
Uncontrolled if printed or copied. Always check for latest version.		Page 4 of 4